

reversible motor - series XV

XV-1M

STANDARD MOTOR
ø30 FLANGE - TAPER SHAFT

X 1 M 25 07 G I I E

Series	X	series XV
Group	1	group 1
Category	M	reversible motor
Displacement	25	3.8
Flange	07	Ø30 STANDARD reversible rotation
Shaft	G	CO002 - Tapered 1:8 - ø14 - M10x1 - key thk.3
Body	IN	inlet - Ø30 Ø12 M6
	OUT	outlet - Ø30 Ø12 M6
Cover	E	with drainage 1/4" BSP

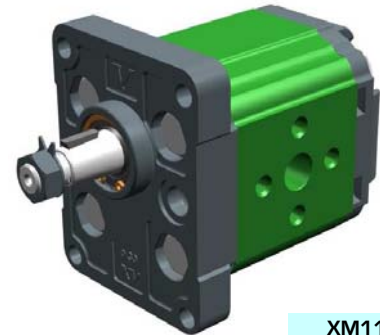

XM113

Technical data table

TYPE	Displacement cm3/rev	Max. Pressure		CODE	
		P1 bar	P3 bar	External drainage	Internal drainage
XV-1M/0.9	0,91	240	280	X 1 M 16 07 G I I E	X 1 M 16 07 G I I F
XV-1M/1.2	1,17	250	290	X 1 M 17 07 G I I E	X 1 M 17 07 G I I F
XV-1M/1.7	1,56	250	290	X 1 M 18 07 G I I E	X 1 M 18 07 G I I F
XV-1M/2.2	2,08	250	290	X 1 M 20 07 G I I E	X 1 M 20 07 G I I F
XV-1M/2.6	2,60	250	300	X 1 M 21 07 G I I E	X 1 M 21 07 G I I F
XV-1M/3.2	3,12	250	300	X 1 M 23 07 G I I E	X 1 M 23 07 G I I F
XV-1M/3.8	3,64	250	300	X 1 M 25 07 G I I E	X 1 M 25 07 G I I F
XV-1M/4.3	4,16	250	300	X 1 M 27 07 G I I E	X 1 M 27 07 G I I F
XV-1M/4.9	4,94	250	300	X 1 M 29 07 G I I E	X 1 M 29 07 G I I F
XV-1M/5.9	5,85	250	300	X 1 M 31 07 G I I E	X 1 M 31 07 G I I F
XV-1M/6.5	6,50	250	300	X 1 M 32 07 G I I E	X 1 M 32 07 G I I F
XV-1M/7.8	7,54	220	260	X 1 M 34 07 G I I E	X 1 M 34 07 G I I F
XV-1M/9.8	9,88	190	230	X 1 M 36 07 G I I E	X 1 M 36 07 G I I F

P1) Max. working pressure - P3) Max. peak pressure

For heavy-duty applications, it is recommended to check the admissible torque of the shaft

Dimensions table

TYPE	Weight kg	A	B	C	D	E	F	D	E	F
		mm	mm	mm	mm	mm	mm	mm	mm	mm
XV-1M/0.9	0,950	78,1	37,3	66,1	ø12	30	M6x1	ø12	30	M6x1
XV-1M/1.2	0,970	79,0	37,8	67,0	ø12	30	M6x1	ø12	30	M6x1
XV-1M/1.7	1,010	80,5	38,5	68,5	ø12	30	M6x1	ø12	30	M6x1
XV-1M/2.2	1,030	82,5	39,5	70,5	ø12	30	M6x1	ø12	30	M6x1
XV-1M/2.6	1,060	84,5	40,5	72,5	ø12	30	M6x1	ø12	30	M6x1
XV-1M/3.2	1,090	86,5	41,5	74,5	ø12	30	M6x1	ø12	30	M6x1
XV-1M/3.8	1,120	88,5	42,5	76,5	ø12	30	M6x1	ø12	30	M6x1
XV-1M/4.3	1,170	90,5	43,5	78,5	ø12	30	M6x1	ø12	30	M6x1
XV-1M/4.9	1,200	93,5	45,0	81,5	ø12	30	M6x1	ø12	30	M6x1
XV-1M/5.9	1,260	97,0	46,8	85,0	ø12	30	M6x1	ø12	30	M6x1
XV-1M/6.5	1,300	98,5	48,0	86,5	ø12	30	M6x1	ø12	30	M6x1
XV-1M/7.8	1,360	103,5	50,0	91,5	ø12	30	M6x1	ø12	30	M6x1
XV-1M/9.8	1,500	112,5	54,5	100,5	ø12	30	M6x1	ø12	30	M6x1

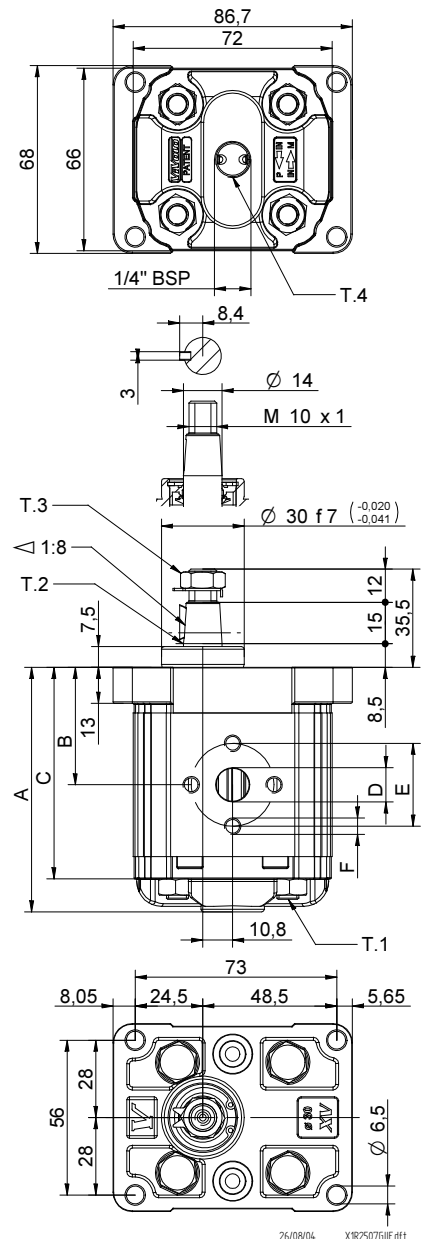

T.1 = 24.5÷29.4 [Nm] - screw tightening torque M8

T.3 = 13 [Nm] - torque wrench setting 17





T.2 = 119.8 [Nm] - admissible shaft torque (N.B. When choosing a shaft, always check the admissible torque).

T.4 = 0.3÷0.5 bar - max. drainage pressure

Table of variations

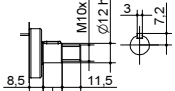
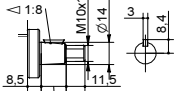
XV-1M

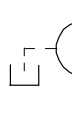
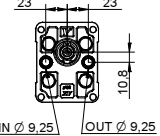
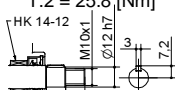
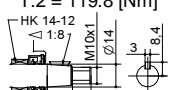
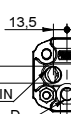
ø30 FLANGE

ø30 FLANGE		Shaft		Cover	
	07	CI001 - Parallel T.2 = 25.8 [Nm]	A	CO002 - Tapered T.2 = 119.8 [Nm]	G
				 External drainage	 Internal drainage
 IN Ø 9,25 OUT Ø 9,25	10	CI001+HK - Parallel T.2 = 25.8 [Nm]	P		
				 IN + OUT + external	 IN + OUT + internal

Displacement	
TYPE	CODE
XV-1M/0.9	16
XV-1M/1.2	17
XV-1M/1.7	18
XV-1M/2.2	20
XV-1M/2.6	21
XV-1M/3.2	23
XV-1M/3.8	25
XV-1M/4.3	27
XV-1M/4.9	29
XV-1M/5.9	31
XV-1M/6.5	32
XV-1M/7.8	34
XV-1M/9.8	36

Standard bodies				
Displacement cm ³ /rev	Standard threads			
	0.9	I - I	B - B	J - J
1.2	I - I	B - B	J - J	Z - Z
1.7	I - I	B - B	J - J	Z - Z
2.2	I - I	B - B	J - J	Z - Z
2.6	I - I	B - B	J - J	Z - Z
3.2	I - I	B - B	J - J	Z - Z
3.8	I - I	B - B	J - J	Z - Z
4.3	I - I	B - B	J - J	Z - Z
4.9	I - I	B - B	J - J	Z - Z
5.9	I - I	B - B	J - J	Z - Z
6.5	I - I	B - B	J - J	Z - Z
7.8	I - I	B - B	J - J	Z - Z
9.8	I - I	B - B	J - J	Z - Z

Table showing standard flange and thread combinations available in stock

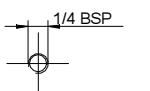
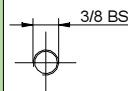
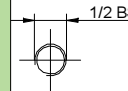
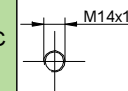
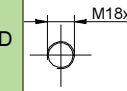
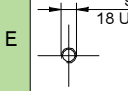
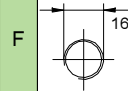
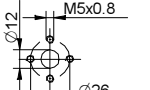
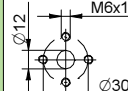
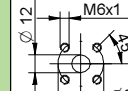
Body (threads/flanges)													
	A		B		C		D		E		F		G
	H		I		J	Closed Body	Z						